



CATALOGUE

Sata Connector



Range Overview

▾ Receptacle to Overmolded with Cable

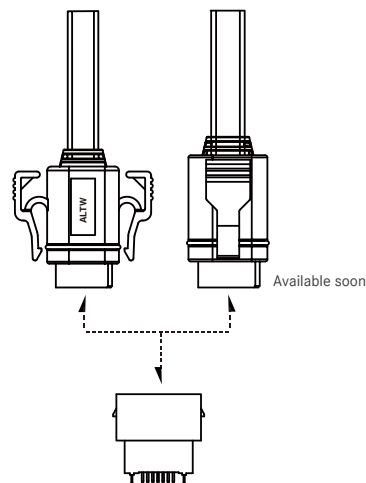

Specification

Identifications	SATA II connector
Description	PCB to Wire
Current Rating	1.5 A
Material	Contacts: Copper Alloy, Gold Plated Connector Body (Housing): LCP / PBT
Waterproof Rating	IP67
Temperature Range	Receptacle: -20°C~80°C Overmolded with Cable: -20°C~80°C
Contact Resistance	≤ 30mΩ
Insulation Resistance	≥ 1000mΩ at DC500V
Durability	500 cycles
More to know	SATA III (upon request)

Ordering Information

	1	2	3	4	5	6	7
Specification							
(SA7) SATA 7 Pin Type							
Type							
(2) SATA II							
							* SATA III upon request
Connector (Housing) Gender							
> For Receptacle / PCB							> For Overmolded with Cable
(P) Female (Socket)							(A) Male (Plug)
Connector Body							
> For Receptacle / PCB							> For Overmolded with Cable
(S) SMD							(L) Cable Latch (Double)
(D) DIP							(P) Cable Latch (Single)
Board Lock / Cable Type							
> For Receptacle / PCB							> For Overmolded with Cable
(TA) Flat Board Lock 2.6mm							(DU) 2 End Cable Type
(TB) Flat Board Lock 1.6mm							(SN) 1 End Cable Type
(FA) Harpoon Board Lock 2.6mm							
(FB) Harpoon Board Lock 3.2mm							
Waterproof Rating							
(7) IP 67							
More Information							
> For Receptacle							> For Overmolded with Cable
(001) Without Cable							(A01) 100MM
							(A05) 500MM

* Design and specification are subject to change without notice.

Physical Dimension

Receptacle

DIP Layout

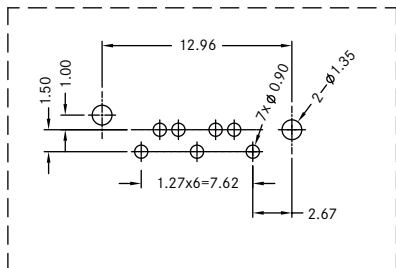

Board Lock Type

Harpoon

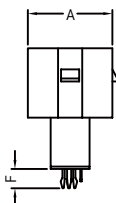

Flate

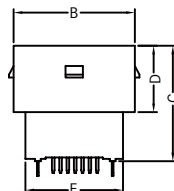
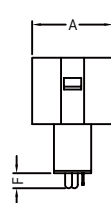

A	B	C	D	E	F
14.0	21.0	20.0	11.5	16.9	2.6
					3.2
14.0	21.0	20.0	11.5	16.9	2.6
					1.6

Receptacle

SMT Layout

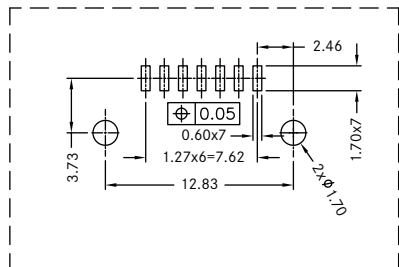

Board Lock Type

Harpoon

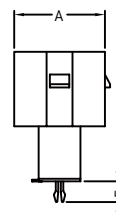

Flate

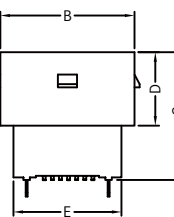
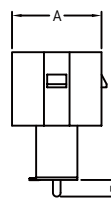

A	B	C	D	E	F
14.0	21.0	20.0	11.5	16.9	2.6
					3.2
14.0	21.0	20.0	11.5	16.9	2.6
					1.6

Overmolded with Cable

Cable Latch (Double)

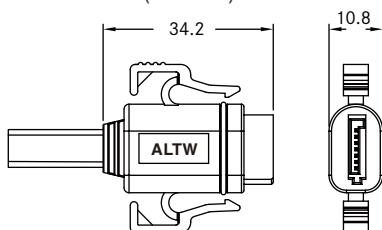

Cable Latch (Single)

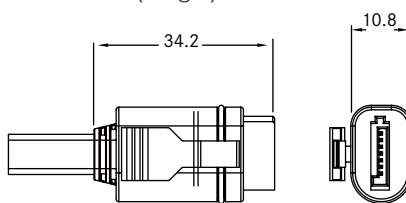

Contact Configuration

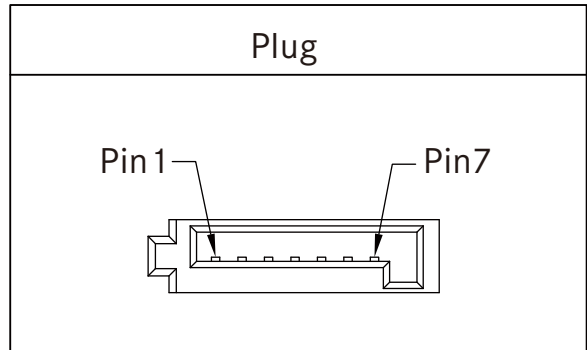
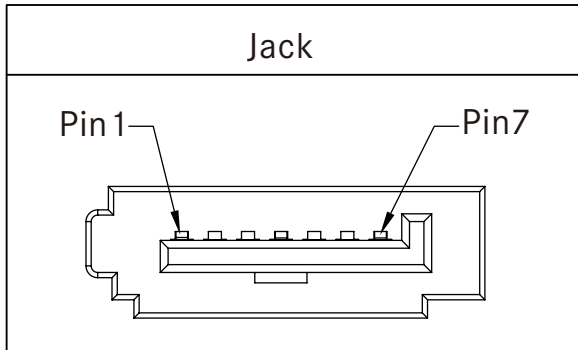

Find Our Standard Products

▾ Receptacle and Mating Pair

	Receptacle> 	Overmolded with Cable
	Jack	Plug
SATA II	SA7-2PDFA-7001 SA7-2PDFB-7001 SA7-2PDTA-7001 SA7-2PDTB-7001 SA7-2PSFA-7001 SA7-2PSFB-7001 SA7-2PSTA-7001 SA7-2PSTB-7001	SA7-2ALDU-7AXX SA7-2APDU-7AXX *Upon request

* Design and specification are subject to change without notice.

Amphenol LTW Technology Co., Ltd. (Headquarter)

9F., No.657-12, Zhongzheng Rd., Xinzhuang Dist., New Taipei City 242, Taiwan
Telephone: +886-2-29085626 Fax: +886-2-29029787
www.amphenolltw.com

Shulin plant, Taiwan

No.10, Shutan St., Shulin Dist., New Taipei City 238, Taiwan

Kunshan plant, China

No. 62 Da Tung Road, Peng Lang Street, Kunshan City , Jiangsu Province, China
Telephone: +86-512-5761-0501
Fax: : +86-512-5761-0515

For further information, please contact :

Sales & Marketing Department | Email : sales@ltw-tech.com



Scan to visit our website